

METTLER TOLEDO

DIVA Operation Manual

Metrologic Stratos Series Scanners

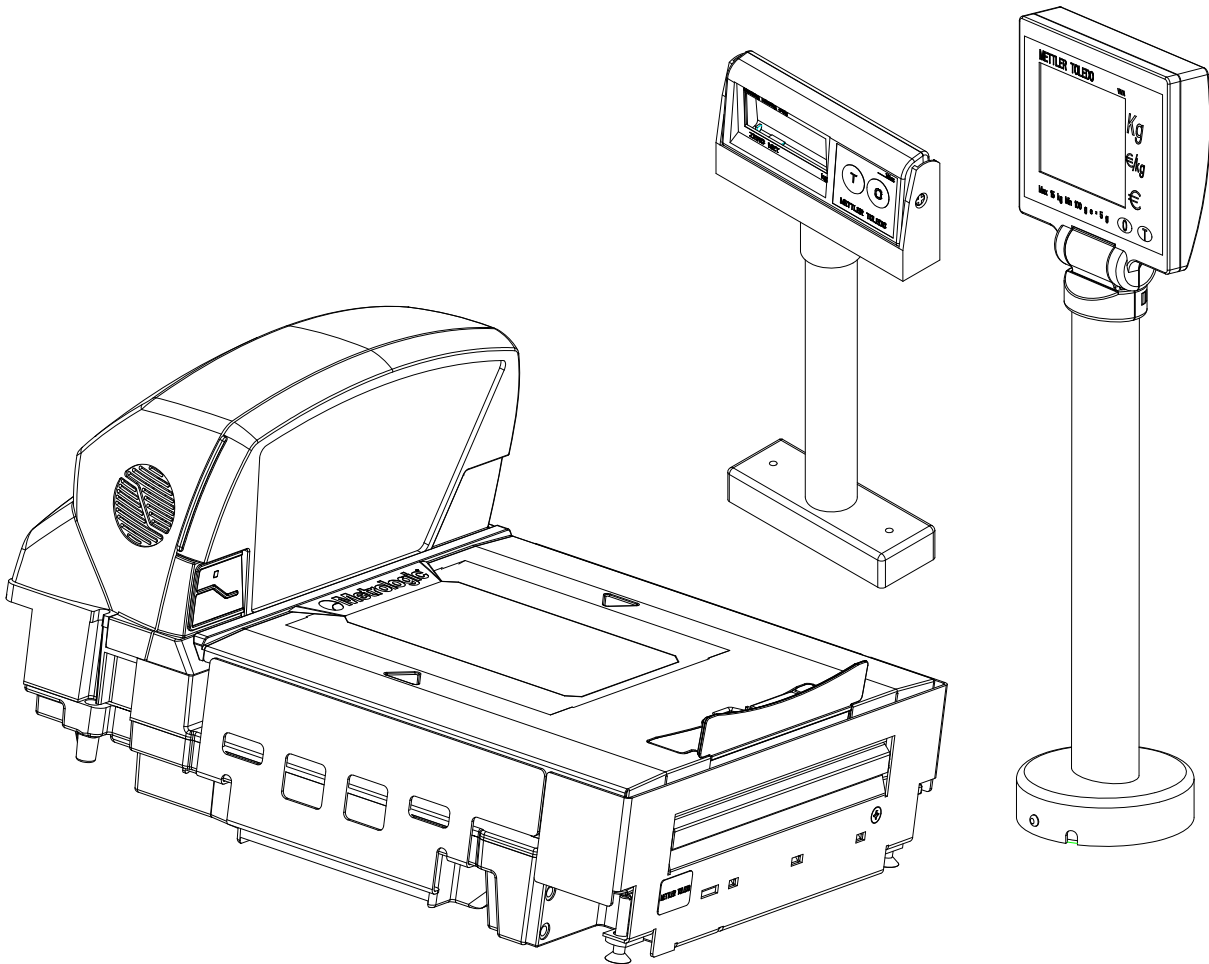

INTRODUCTION

This publication is solely as a guide for individuals who purchased the METTLER TOLEDO Diva scale.

Information regarding METTLER TOLEDO Technical Training may be obtained by writing to:

**METTLER TOLEDO
1900 Polaris Parkway
Columbus, Ohio 43240-2020
(614) 438-4511**

©Mettler-Toledo, LLC 2012



No part of this manual may be reproduced or transmitted in any form or by any means, electronic or mechanical, including photocopying and recording, for any purpose without the express written permission of Mettler-Toledo, LLC.

U.S. Government Restricted Rights: This documentation is furnished with Restricted Rights.

**METTLER TOLEDO RESERVES THE RIGHT TO MAKE REFINEMENTS OR CHANGES
WITHOUT NOTICE.**

Precautions

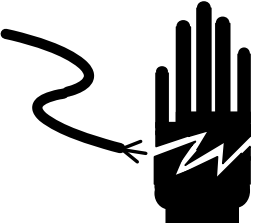

READ this manual **BEFORE** operating or servicing this equipment.

	 WARNING
	ONLY PERMIT QUALIFIED PERSONNEL TO SERVICE THIS EQUIPMENT. EXERCISE CARE WHEN MAKING CHECKS, TESTS AND ADJUSTMENTS THAT MUST BE MADE WITH POWER ON. FAILING TO OBSERVE THESE PRECAUTIONS CAN RESULT IN BODILY HARM.

FOLLOW these instructions carefully.

	 WARNING
	FOR CONTINUED PROTECTION AGAINST SHOCK HAZARD CONNECT TO PROPERLY GROUNDED OUTLET ONLY. DO NOT REMOVE THE GROUND PRONG.

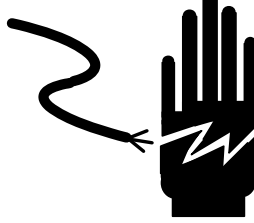
SAVE this manual for future reference.

	 WARNING
	DISCONNECT ALL POWER TO THIS UNIT BEFORE REMOVING THE FUSE OR SERVICING. FAILURE TO DO SO MAY RESULT IN BODILY INJURY OR PROPERTY DAMAGE.

DO NOT allow untrained personnel to operate, clean, inspect, maintain, service, or tamper with this equipment.

 CAUTION
BEFORE CONNECTING/DISCONNECTING ANY INTERNAL ELECTRONIC COMPONENTS OR INTERCONNECTING WIRING BETWEEN ELECTRONIC EQUIPMENT ALWAYS REMOVE POWER AND WAIT AT LEAST THIRTY (30) SECONDS BEFORE ANY CONNECTIONS OR DIS-CONNECTIONS ARE MADE. FAILURE TO OBSERVE THESE PRECAUTIONS COULD RESULT IN DAMAGE TO OR DESTRUCTION OF THE EQUIPMENT OR BODILY HARM.

ALWAYS DISCONNECT this equipment from the power source before cleaning or performing maintenance.

 CAUTION
OBSERVE PRECAUTIONS FOR HANDLING ELECTROSTATIC SENSITIVE DEVICES.

CALL METTLER TOLEDO for parts, information, and service.

Contents

INTRODUCTION	1
DIMENSIONS	5
INSTALLATION.....	6
ENVIRONMENT	6
CONTENTS OF PACKAGING	6
SETUP.....	6
DISPLAY AND KEYBOARD	8
DISPLAY	8
KEYBOARD.....	9
CURSORS	10
OPERATIONS.....	11
WEIGHING AND COMMUNICATION	11
BACKLIGHT FUNCTION	11
RE-ZERO FUNCTION	11
TARE FUNCTION.....	11
SETUP	12
SETUP SOFT SWITCHES.....	13
SOFT SWITCHES – DEFAULT SETTINGS	15
APPENDIX	16
ERRORS	16
CLEANING AND MAINTENANCE.....	16
SPECIFICATIONS	16
ACCESSORIES.....	17

Introduction

Please read this instruction manual carefully. This manual is intended for use with all Diva Weigh Only and Price Computing scales.

The Diva scale is combined with a scanner for full featured Checkout applications. The Diva scale is a high precision weighing instrument. It is designed for applications where product is sold directly to customers and has to be approved by local Weights and Measures officials.

All of our equipment is assembled, tested and packed with great care. If you find something that does not meet your expectations, please contact us immediately.

This scale will provide years of accurate weighing if properly used and maintained. Please handle it as you would any piece of sensitive electronic equipment.

GEO-Value

The GEO-Value of verified scales explains for which location of use the scale has been verified. This GEO-Value is shown on the weight display shortly after power is applied to the scale.

Country	Geo-Width	Geo-Value (default)
Austria	46°22' – 49°01'	18
Belgium	49°30' – 51°30'	20
Bulgaria	41°41' – 44°13'	16
Croatia	42°24' – 46°32'	18
Czechia	48°34' – 51°03'	20
Denmark	54°34' – 57°45'	23
France	41°20' – 51°00'	19
Finland	59°48' – 70°05'	25
Germany	47°00' – 55°00'	20
Greece	34°48' – 41°45'	15
Hungary	45°45' – 48°35'	19
Ireland	51°05' – 55°05'	22
Iceland	63°17' – 67°09'	26
Italy	35°47' – 47°05'	17
Latvia	55°30' – 58°04'	23
Luxembourg	49°27' – 50°11'	20
Liechtenstein	47°03' – 47°14'	18
Lithuania	53°54' – 56°24'	22
Netherlands	50°46' – 53°32'	20
Norway	57°57' – 71°11'	24
Poland	49°00' – 54°30'	21
Portugal	36°58' – 42°10'	15
Romania	43°37' – 48°15'	18
Sweden	55°20' – 69°04'	24
Switzerland	45°49' – 47°49'	18
Slovakia	47°44' – 49°46'	19
Slovenia	45°26' – 46°35'	18
Spain	36°00' – 43°47'	15
Turkey	35°51' – 42°06'	16
United Kingdom	49°00' – 62°00'	21



FOR YOUR NOTES:

Mettler-Toledo (ChangZhou) Measurement Technology Ltd.
 Legal Metrology

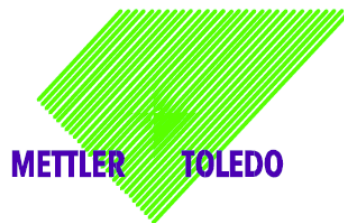

Declaration of Conformity
 Konformitätserklärung
 Déclaration de conformité
 Declaración de Conformidad
 Conformiteitsverklaring
 Dichiarazione di conformità

We, Wir, Nous, Nosotros, Wij, Noi

Mettler-Toledo (ChangZhou) Measurement Technology Ltd.
 No.111, West TaiHu Road, XinBei District, ChangZhou, JiangSu, 213125, P.R.China

declare under our sole responsibility that the product,
 erklären, in alleiniger Verantwortung, dass dieses Produkt,
 déclarons sous notre seule responsabilité que le produit,
 declaramos, bajo nuestra sola responsabilidad, que el producto,
 verklaren onder onze verantwoordelijkheid, dat het product,
 dichiariamo sotto nostra unica responsabilità, che il prodotto,

Model/Type: DIVA SN ≥60604796MH

to which this declaration relates, is in conformity with the following standard(s) or other normative document(s).
 auf das sich diese Erklärung bezieht, mit der/den folgenden Norm(en) oder Richtlinie(n) übereinstimmt.
 auquel se réfère cette déclaration est conforme à la (aux) norme(s) ou au(x) document(s) normatif(s).
 al que se refiere esta declaración es conforme a la(s) norma(s) u otro(s) documento(s) normativo(s).
 waarnaar deze verklaring verwijst, aan de volende norm(en) of richtlijn(en) beantwoordt.
 a cui si riferisce questa dichiarazione è conforme alla/e sequente/i norma/e o documento/i normativo/i.

EC marking	EC Directive	Applicable Standards	Approval No.
	2006/95/EC Low Voltage	EN60950-1:2006	
	2004/108/EC EMC	EN61326:2006 (Class B) EN61000-3-3	
 1)	2009/23/EC Non-automatic weighing instruments	EN45501	T6941

1) Applies only to certified non-automatic weighing instruments. POS systems which are covered by a test certificate and which have undergone EC conformity assessment are included.
 Gilt nur für geeichte nicht selbsttätige Waagen. Angeschlossene Kassensysteme, für die ein Prüfschein / Testzertifikat vorliegt und die einem Konformitätsfeststellungsverfahren unterzogen wurden, sind eingeschlossen.
 S'applique uniquement aux instruments de pesage à fonctionnement non automatique vérifiés. Les Terminaux Point de Vente qui sont couverts par un certificat d'essai et qui ont reçu l'évaluation de conformité sont inclus.
 Applicabile solamente a strumenti di pesatura a funzionamento non automatico approvati CE. Sono inclusi i sistemi POS coperti da un test certificate e sottoposti a valutazione di conformità CE.
 Enkel van toepassing op gecertificeerde Niet Automatische Weegwerktuigen. Ook geldig voor aangesloten kassasystemen met een geldig testcertificaat en een EC konformiteitsonderzoek, dat succesvol is afgerond.
 Aplicable solamente a instrumentos de pesaje de funcionamiento no automático aprobados y verificados. Incluye sistemas POS que disponen de Certificados de Ensayo de elementos y que han pasado una evaluación de Conformidad CE.

2009-12-17
 Mettler-Toledo (ChangZhou) Measurement Technology Ltd.

Yang JiaWu
 QA Manager

Important notice concerning verified instruments see overleaf!

Mettler-Toledo (ChangZhou) Measurement Technology Ltd.

Legal Metrology

Important notice for verified weighing instruments in EC-countries



Weighing Instruments verified at the place of manufacture bear the preceding mark on the packing label and a green "M" sticker on the descriptive plate. They may be put into use immediately.



Weighing Instruments which are verified in two steps have no green "M" on the descriptive plate and bear the preceding identification mark on the packing label. The second step of the verification must be carried out by the approved Mettler-Toledo service or by the W&M authorities. Please contact your Mettler-Toledo organization.

The first step of the verification has been carried out at the manufacturing plant. It comprises of all tests according to EN 45501-8.2.2. If national regulations in individual countries limit the period of validity of the certification, then the users of such a weighing instrument are themselves responsible for its timely re-certification.

Wichtiger Vermerk für geeichte Waagen in EU-Ländern



Werksgeeichte Waagen tragen vorstehendes Kennzeichen auf dem Packetkett und einen grünen "M"-Kleber auf dem Eichschild. Sie dürfen sofort in Betrieb genommen werden.



Waagen, die in zwei Schritten geeicht werden und kein grünes "M" auf dem Eichschild haben, tragen vorstehendes Kennzeichen auf dem Packetkett. Der zweite Schritt der Eichung ist durch den behördlich anerkannten Mettler-Toledo Service oder durch den Eichbeamten durchzuführen. Bitte nehmen Sie mit dem Mettler-Toledo Kundendienst Kontakt auf.

Der erste Schritt der Eichung wurde im Herstellerwerk durchgeführt. Er umfasst alle Prüfungen gemäß EN45501-8.2.2. Sofern gemäß den nationalen Vorschriften in den einzelnen Staaten die Gültigkeitsdauer der Eichung beschränkt ist, ist der Betreiber einer solchen Waage für die rechtzeitige Nacheichung selbst verantwortlich.

Remarque Importante pour les Instruments de pesage vérifiées dans les pays membre de l'Union Européenne



Les instruments de pesage vérifiés en usine portent l'identification ci-contre sur leur emballage et un autocollant "M" vert sur la plaque d'identification. Ils peuvent être utilisés après leur installation.



Les instruments de pesage vérifiés en deux étapes portent l'identification ci-contre sur leur emballage et n'ont pas d'autocollant "M" vert sur la plaque d'identification. La seconde étape de la vérification doit être effectuée par le service technique Mettler-Toledo autorisé responsables. Veuillez s.v.p. contacter le service technique Mettler-Toledo.

La première étape de la vérification a été effectuée en usine. Cela comprend tous les essais suivant la norme EN45501-8.2.2. Dans la mesure où la durée de la vérification est limitée en fonction des prescriptions nationales dans les différents pays, l'utilisateur d'une telle balance est lui-même responsable de la vérification ultérieure dans les délais.

Nota importante para básculas verificadas en países de la UE



Las básculas verificadas en origen, llevan esta indicación en la etiqueta del embalaje y disponen de la etiqueta "M" sobre fondo verde en la placa de características. Pueden ser utilizadas inmediatamente.



Las básculas cuya verificación se realiza en dos fases, llevan esta indicación en la etiqueta del embalaje y NO llegan con la etiqueta "M" verde en la placa de características. La segunda fase de la verificación debe ser realizada por personal Mettler-Toledo acreditado, o por la autoridad competente. Rogamos contacten con el Servicio Técnico de Mettler-Toledo.

La primera fase de la verificación ha sido realizada en origen. Incluye todos los ensayos según lo norma EN45501-8.2.2. El plazo de validez de la verificación está limitado por las normas de cada estado. El usuario es responsable de la solicitud para las verificaciones reglamentarias posteriores a la puesta en servicio de la báscula

Nota Importante per la balance approvate nei paesi UE



Le balance verificate in fabbrica portano questo contrassegno sull'etichetta dell'imballo e con il sigillo "M" su stando verde sulla targhetta metrological possono essere messe in uso immediatamente.



Le balance che vengono verificate in due fasi, portano questo contrassegno sull'etichetta dell'imballo e non portano il sigillo "M" sulla targhetta metrological. La seconda fase della verifica dev'essere eseguita dal servizio assistenza Mettler-Toledo autorizzato, oppure dalla autorità competente. Prego contattate il vostro servizio assistenza Mettler-Toledo.

La prima fase della verifica è stata eseguita dal produttore e comprende tutte le prove previste dalla norma EN 45501-8.2.2. Se la durata di validità della verifica è limitata in accordo con le prescrizioni nazionali vigenti nei singoli paesi, l'utilizzatore stesso di una bilancia di tale tipo sarà responsabile dell'esecuzione, entro le date di scadenza previste, delle verifiche periodiche.

Dimensions

High tower version for Price Computing

Short tower version for Weigh Only

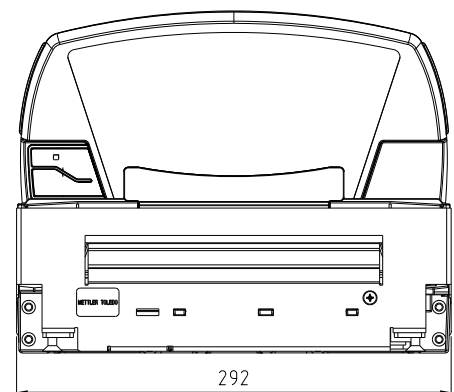
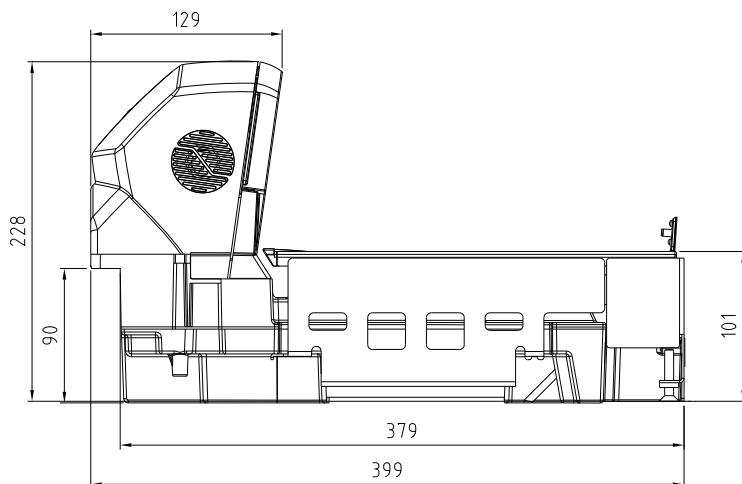
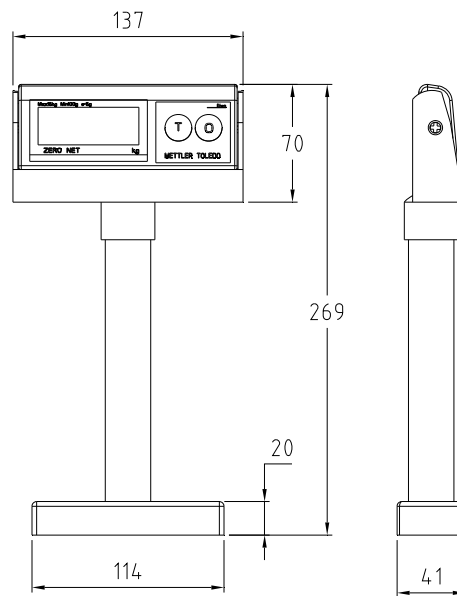
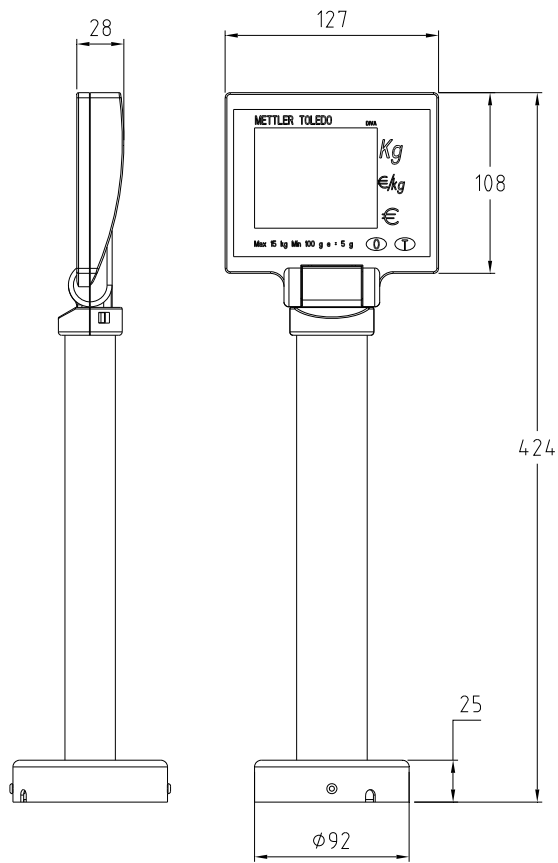

Installation

Environment

Before you install your DIVA scale keep in mind the following factors, which might have a negative influence on the scale's operation:

- Vibration diminishes the scale's ability to measure accurately. Excessive vibration from equipment such as conveyors can cause inaccurate and non-repeatable readings.
- Be sure the scale is leveled properly.
- Air currents can also diminish the scale's performance. Avoid placing the scale in front of or directly under air vents.
- Other than items being weighed, keep the scale free from objects rubbing or pressing against the platter.

Contents of Packaging

Package contents for all DIVA units include:

- DIVA scale base
- Operation Manual
- Display Cable
- Tower included and attachment hardware (The optional display may be packed separately)
- Communication and Display cables (from scale to scanner)
- Sealing Kit

Setup

1. Open the box, carefully remove the packing material, take all items out of the carton.
2. Attach the display as described below, depending on which version of scale you ordered:

For Price Computing Version:

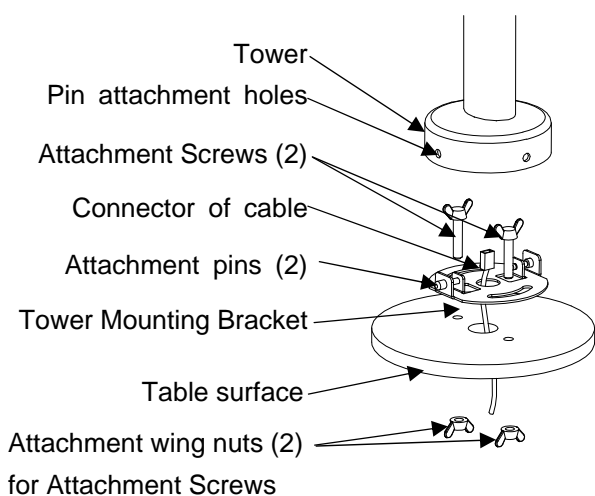

- A: Pull the connector of the cable through the holes of the table surface and tower mounting bracket;
- B: Put (2) screws through the (2) arch holes on the bracket and (2) holes on the table surface;
- C: Attach cover to the surface of table with (2) nuts.
- D: Connect the cable to the connector at the bottom of the tower display
- E: Attach the base of the display to the mounting bracket by insuring that the (2) pins on the bracket are inserted in the holes of the base to attach the tower and snap the tower into place.

For Weigh Only Version:

The Weigh Only version comes with a tower mount.

Assemble the Weigh Only tower as is illustrated here:

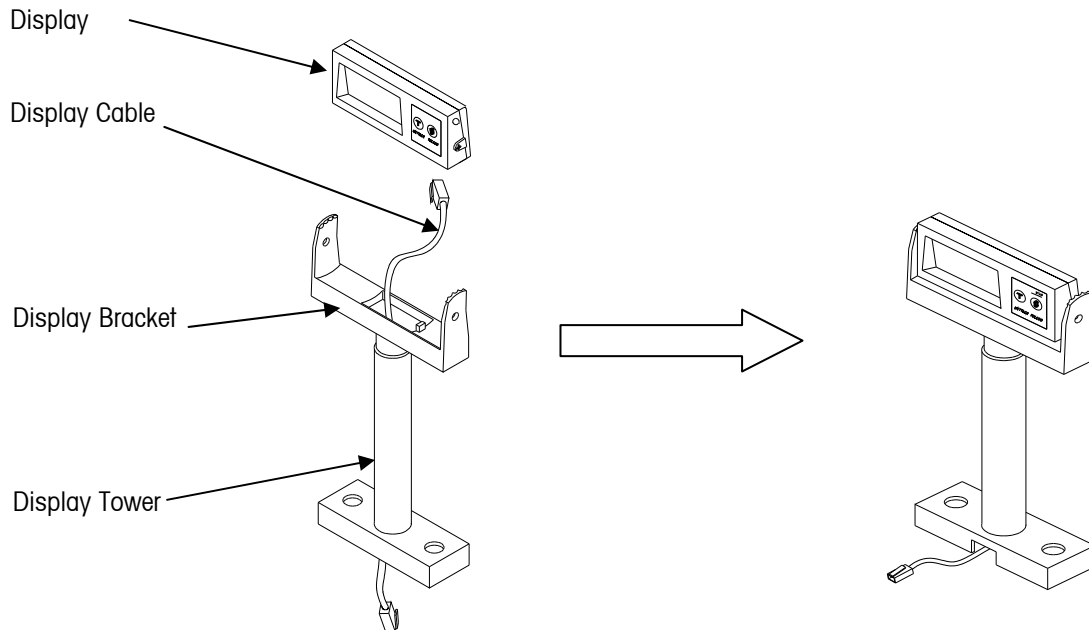

2. Set the scale base on a sturdy, level surface. Level the scale by turning the adjustable feet on the bottom of the unit. Adjust the feet until the level bubble is in the center of the circle.

Bubble indicator:

Correct



Wrong



3. Put the platter on top of the DIVA scale base.
4. Connect the tower display cable to the scanner.
5. Attach the communications cables between the scanner and the POS.

Power up sequence

Note: Before powering on the DIVA scale, always make sure there is nothing on the platter.

Apply power to the scanner. The scale will go through a series of self-tests and then will proceed to normal operating mode. The power-up sequence is as follows:

1. All segments of the display characters are lit. This verifies operation of all segments;
2. The scale displays the country code and GEO code, software part number and revision.
3. The scale then captures zero and is ready for normal operation.

Display and Keyboard

Display

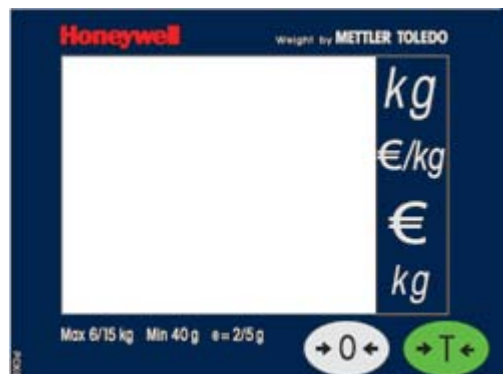
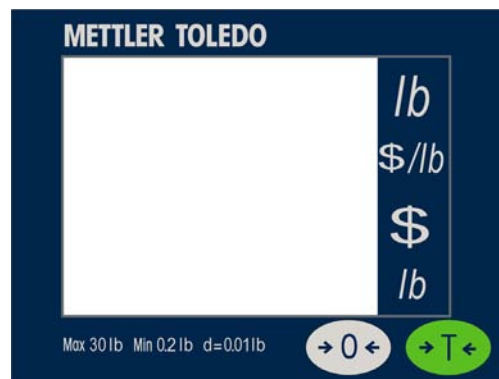
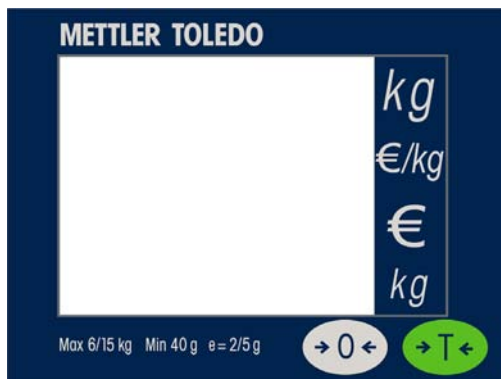

Price Computing Version:



Weight Only Version:



Keyboard

	<p>Used to return the scale to gross zero if drifting should occur.</p>
	<p>Tare key.</p>

Cursors

NET	Lights when tare is entered.
Zero	Lights when gross weight is zero.

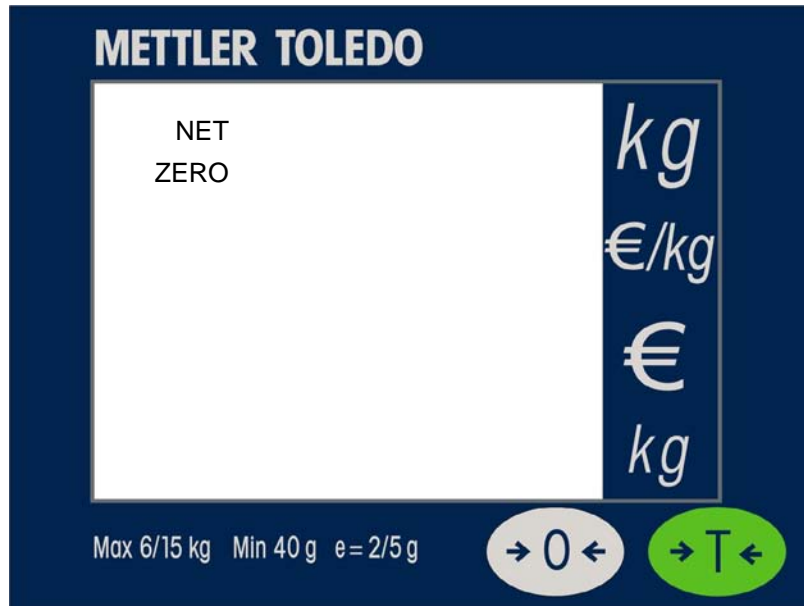

Operations

Weighing and Communication

Place the item to be weighed on the platter, the weight will be displayed.

Remote ASCII commands can control all other functions including data transfer, zero, and tare, depending on the protocol.

Backlight function

Diva is equipped with a backlight for the display. To switch on the backlight, press and hold the "ZERO" key for about 3 seconds until the backlight turns on. Use the same procedure to switch the backlight off.

Re-zero function

There are two ways to re-zero the scale:

1. Power-up Zero
2. Push button Zero

Power-up Zero

The scale will automatically capture zero when it is turned on. The power-up zero capture range is +/-10% of the scale capacity. When the scale is turned on with a weight on the platter of more than +/-10% of the capacity, the scale will not capture zero (the weight display will show "----") and the scale will not be ready for use. After removing the weight the scale will capture "zero".

Push button Zero

The ZERO key re-zeros the scale over a range of +/-2% of the scale capacity. To use this function, the scale must be in the gross weighing mode (NET cursor must be off) and in a non-motion condition. When the weight on the platter is more than +/-2% of the scale capacity, the depression of the zero key will not be accepted.

Tare Function

The Tare Key allows you to subtract weight from the platter for items like containers that will be used to hold the item being weighed.

Place the empty container or wrapping material on the platter and Press the Tare Key.

Place the item to be weighed in the container or on the wrapping material and onto the platter.

Note: A Tare command can be sent from a POS through the Diva's serial connection. Whatever method is used to start a transaction must continue to be used until the transaction is over. If the push button is used first, a remote tare command will not work. Conversely, if a remote tare is used then the push button will not work until the transaction is complete and the scale has returned to zero.

Setup

This mode allows an operator to change certain soft switches directly from the keyboard.



Press and hold the key until "grP 1" and "CONF" is displayed. This will take about 8 seconds. The scale is configurable for your specific needs with a special interactive set up procedure. In order to access the various prompts, you must utilize the following keys during the scale setup mode.



This key is used to confirm the choice and then go to the next step.



This key is used to step through the set up groups. Once a group is accepted, this key is used to select the soft switch settings

Setup Soft Switches

Group.Step	Function	Possible Selections
Group 1		
1.3	Beeper	ON - Scale will "beep" when a key is pressed. OFF - No sound is made when a key is pressed.
1.4	Zero Cursor	ON - Display zero cursor. OFF - Disable zero cursor.
1.5	Decimal point	ON - . OFF - ,
Group 2		
2.4	Digital Filter Selection	0 - Minimal 1 - Low (Used for Normal use) 2 - Medium 3 - High (Used when there is lots of vibration)
2.7	Display (1 or 4 Line)	0 - None 1 - 1 Line 2 - 4 Line
2.8	Display Update Rate	0-100 - Adjust display rate

Group.Step	Function	Possible Selections
Group 3		
3.1	Baud rate	0 = 1200 1 = 2400 2 = 4800 3 = 9600 4 = 19200 5 = 38400
3.2	Parity	0 = None 1 = Even 2 = Odd
3.3	Data	0 = 7 data bit 1 = 8 data bit
3.4	Bit stop	0 = None 1 = 1 stop bit 2 = 2 stop bit
3.5	Chose Protocol	0 = Disabled 1 = NCI-ECR (WO) 2 = (reserved) 3 = 8217 Mettler-Toledo (WO) 4 = 8213 Mettler-Toledo (WO) 5 = EPOS 1(WO) 6 = EPOS 2(WO) 7 = (reserved) 8 = Dialog 06 (PC) 9 = Dialog 04/02 (PC) 10 = (reserved) 11 = ICL (WO) 12 = Shekel (WO) 13 = RIVA 5462 (WO) 14 = IP3 (PC) 15 = (reserved) 16 = (reserved)
3.6	Inter-character Delay	0 – None 1 – 1 ms ... 9 – 9 ms
3.7	Protocol Options	For NCI-ECR protocol, 0 – 4 byte status reporting 1 – 2 byte status reporting
SAVE	Save or abort setting	SAVE = save all setting and return to weighing mode ABORT = abort all setting and return to weighing mode
Group 4		
4.1	Weight Change	00 - No Weight Change Required yy - 01 to 99 weight change divisions required
4.2	Return to Zero	0 – No Return to Zero Required 1 - Return to Zero Active
EXIT		
SAVE	Save or abort setting	SAVE – save all settings and return to weighing mode ABORT – abort all settings and return to weighing mode

* PC - price computing version, WO - weigh only version.

Soft Switches – Default Settings

Function	PC Germany/ (Europe)	France	USA	Austria	Spain/ Portugal	Belgium/ Poland/ England	Italy	Kazakhstan/ Swiss	Ukraine	Russia	Hungary	Slovakia	Czechia	General Export	China	Canada
Group 1																
1.3 Beeper	On	On	Off	On	On	On	On	On	On	On	On	On	On	On	On	On
1.4 Zero Cursor	Off	Off	On	Off	Off	Off	Off	Off	Off	Off	On	Off	Off	On	On	On
1.5 Decimal Point	Off (.)	Off (.)	On (.)	Off (.)	Off (.)	Off (.)	Off (.)	Off (.)	Off (.)	Off (.)	On (.)	Off (.)	Off (.)	On (.)	On (.)	On (.)
Group 2																
2.4 Digital Filter	1 (Low)	1 (Low)	1 (Low)	1 (Low)	1 (Low)	1 (Low)	1 (Low)	1 (Low)	1 (Low)	1 (Low)	1 (Low)	1 (Low)	1 (Low)	1 (Low)	1 (Low)	1 (Low)
2.7 Display Type	2 (4Line)	1 (1Line)	1 (1Line)	1 (1Line)	1 (1Line)	1 (1Line)	1 (1Line)	1 (1Line)	1 (1Line)	1 (1Line)	1 (1Line)	1 (1Line)	1 (1Line)	1 (1Line)	1 (1Line)	1 (1Line)
2.8 Display Update Rate	2	2	2	2	2	2	2	2	2	2	2	2	2	2	2	2
Group 3																
3.1 Baud Rate	3 (9.6kb)	3 (9.6kb)	5 (38.4kb)	3 (9.6kb)	3 (9.6kb)	3 (9.6kb)	3 (9.6kb)	3 (9.6kb)	3 (9.6kb)	3 (9.6kb)	1 (2.4kb)	3 (9.6kb)	3 (9.6kb)	3 (9.6kb)	3 (9.6kb)	3 (9.6kb)
3.2 Parity	2(odd)	1(even)	0(none)	1(even)	1(even)	1(even)	1(even)	1(even)	1(even)	1(even)	1(even)	1(even)	1(even)	1(even)	1(even)	1(even)
3.3 Data Bits	0 (7bits)	0 (7bits)	1 (8bits)	0 (7bits)	0 (7bits)	0 (7bits)	0 (7bits)	0 (7bits)	0 (7bits)	0 (7bits)	0 (7bits)	0 (7bits)	0 (7bits)	0 (7bits)	0 (7bits)	0 (7bits)
3.4 Stop Bit	1	1	1	1	1	1	1	1	1	1	1	1	1	1	1	1
3.5 Protocol	8(Diag06)	1(NC1)	1(NC1)	1(NC1)	1(NC1)	1(NC1)	1(NC1)	1(NC1)	1(NC1)	1(NC1)	5(EPOS1)	1(NC1)	1(NC1)	1(NC1)	1(NC1)	1(NC1)
3.6 Protocol Options	0	0	0	0	0	0	0	0	0	0	0	0	0	0	0	0
3.7 Intercharacter Delay	0	0	0	0	0	0	0	0	0	0	0	0	0	0	0	0
Group 4																
4.1 Weight Change	0	0	0	0	0	0	0	0	0	0	10	0	0	0	0	0
4.2 Return to Zero	0	0	0	0	0	0	0	0	0	0	0	0	0	0	0	0

PC – Price Computing, WO – Weigh Only

Appendix

Errors

The Diva will display an error message if a scale problem or incorrect keyboard entry is sensed. The error codes are:

E 11	RAM error	Cycle power to the scale. For continued problems call METTLER TOLEDO for replacement
E 16	ROM error	
E 18	EEPROM error	
E 20	Calibration error	Cycle power to the scale and restart calibration.
E 28	Transmission Error	Reset Scale
nnnnnn In weight display	Over capacity	Remove weight from Platter, if that does not work try cycling the power to the scale. For continued problems call METTLER TOLEDO for replacement.
nnnnnn in total price display	Over 9999.99	
uuuuuu In weight display	Under zero	Place the platter on the scale. Either press the Zero Key or cycle power to the scale. For continued problems call METTLER TOLEDO for replacement.

Cleaning and Maintenance

- Remove power by removing the line cord or transformer from the wall outlet.
- Use a clean, damp cloth to wipe the exterior surfaces.
- DO NOT use solvents and chemicals to clean the unit.
- DO NOT attempt to remove the cover or perform service or maintenance on the internal parts of the scale.
- Excess liquids spilled onto the scale should be removed and the scale cleaned immediately.

Specifications

Capacity	: 15 and 6kg Multi-Interval
Divisions	: 5 and 2 grams Multi-Interval
Weight display	: 5 digits
Unit price display	: 6 digits (price computing version only)
Total price display	: 6 digits (price computing version only)
Tare display	: 4 digits (price computing version only)
Operating temperature	: -10°C to +40°C
Storage temperature	: -25°C to +50°C
Plug in Power supply	: Power supplied via scanner power supply

Specifications are subject to change without notice.

Accessories

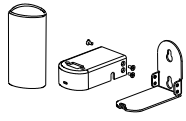
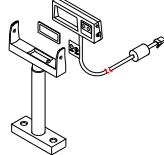
CIMF	Description	Illustration
71208240	VIVA Wall Mount Display Accessory	
Call your local MT Sales Representative	Weight Only Dual Display Kit	



METTLER TOLEDO
1900 Polaris Parkway
Columbus, Ohio 43240-2020

P/N: 72191203

METTLER TOLEDO® is a Trademark of Mettler-Toledo, LLC
©2012 Mettler-Toledo, LLC